

TAXATION

BY

PRADEEP PRAJAPATI

DIRECT TAX

Chapter 1 :

Basic Concept

Tax

Source of Revenue for Govt. (Article 246)

DIRECT TAX

Burden of tax cannot be shifted to other person

Eg. Income tax, Profession tax etc.

INDIRECT TAX

Burden of tax is shifted to other person

Eg. GST, Custom Duty etc.

INCOME TAX

As per Income Tax Act, 1961 Income Tax is levied on Total Income of a person earned during the Previous year immediately preceding the Assessment year.

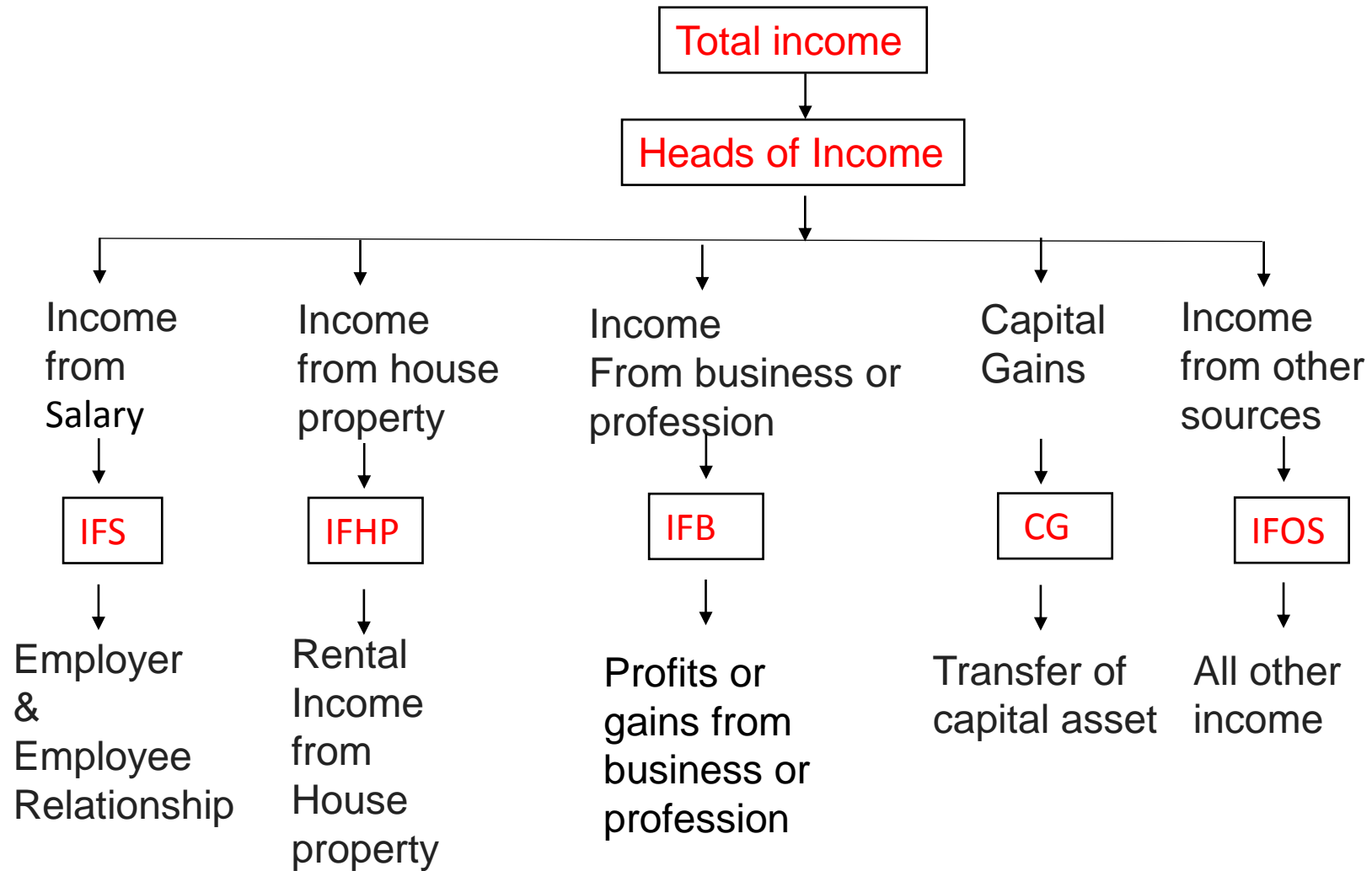

PERSON

- 1) **Individual** :- Natural Person
- 2) **HUF**:- Hindu Undivided Family
- 3) **Company** :- Indian company, foreign company or entity declared by CBDT as company
- 4) **Firm** :- Partnership Firm, LLP.
- 5) **AOP/BOI**:- Association of person (Natural and Artificial), Body of Individual (only Natural Person)
- 6) **Local Authority**:- Municipal corporation, Gram Panchayat etc.
- 7) **Artificial Juridical Person**:- Created under special Act. e.g. LIC, University etc...

Previous year :- It means the financial year immediately preceding the assessment year.

Assessment year :- Period of 12 months Commencing on 1st April every year.

Assessment:- Process of computing Income and Tax on income.

Assessee:- It means a person by whom any tax or any other sum of money is payable under the Act.

Chapter 2. Residential status & Scope of Total Income

Residential status of Individual

<u>Basic conditions [Sec 6(1)]</u>	No. of days stay in India	Satisfied or not satisfied
1) Stay in India for 182 days or more in current P.Y. OR 2) Stay in India for 60 days or more in current PY. [AND] 365 days or more during Last 4 PY's		
<u>Additional conditions [sec. 6(6)]</u> 1) Resident for 2 PY or more in Last 10 PY's [AND] 2) Stay in India for 730 days or more during Last 7 PY's.		

*Imp. Points:

1. If anyone Basic condition is satisfied then person is Resident otherwise Non-Resident
2. If a person is Resident then check additional condition.
3. If Additional condition is satisfied then ROR Otherwise RNOR.

Exceptional case (2nd Basic condition not applicable)

- 1) Indian citizen Leaving India for **employment** Outside India.
- 2) Indian citizen being a **crew member** of **Indian ship**, Leave India during PY.
- 3) Indian citizen or person of Indian origin **comes to India** for **visit** & his total income. is up to Rs **15 lakhs** (other than foreign income).

Additional Imp Point :-

- 1) Indian citizen or POI comes to India for visit having total income more than Rs 15 lakh then 2nd basic condition will be applicable **but instead of 60 days consider 120 days.**
- 2) If above person (point 1) stay in India for 120 days or more but less than 182 days then he will be treated as RNOR. (Don't check Additional conditions)
- 3) If above person (point 1) is **not resident in any country** & is not liable to pay tax in any other country, then he will be **deemed to R but NOR.**

Income Tax

Computation of Total Income

Particulars	Amt	
1) Income From Salary	XX	IFS
2) Income From House Property	XX	IFHP
3) Income From Business/profession	XX	IFB
4) Capital Gains (STCG / LTCG)	XX	CG
5) Income From Other Sources	<u>XX</u>	IFOS
GROSS TOTAL INCOME	XXX	
<u>Less: Deduction u/ch. VI-A</u>	<u>XX</u>	
NET TAXABLE INCOME	<u>XXX</u>	

↓
Tax@- %

Income Tax Department

A.—Salaries

Salaries.

15. The following income shall be chargeable to income-tax under the head "Salaries"—

- (a) any salary due from an employer or a former employer to an assessee in the previous year, whether paid or not;
- (b) any salary paid or allowed to him in the previous year by or on behalf of an employer or a former employer though not due or before it became due to him;
- (c) any arrears of salary paid or allowed to him in the previous year by or on behalf of an employer or a former employer, if not charged to income-tax for any earlier previous year.

Explanation 1.—For the removal of doubts, it is hereby declared that where any salary paid in advance is included in the total income of any person for any previous year it shall not be included again in the total income of the person when the salary becomes due.

Explanation 2.—Any salary, bonus, commission or remuneration, by whatever name called, due to, or received by, a partner of a firm from the firm shall not be regarded as "salary" for the purposes of this section.

Income From Salary

Important Points

1. Income is taxable under this head if there is Employer & Employee Relationship.
2. Salary is taxable on Due OR Receipt basis whichever is earlier.
3. Salary received by Partner shall be taxable under the head IFB.
4. Salary received by MP/MLA/MLC shall be Taxable under the head IFOS.
5. Payment received by Director of the company depends on the terms of appointment.
6. Contract of service shall be treated as IFS
7. Contract for service shall be treated as IFB
8. Salary forgone is always Taxable (It is mere application of income)
9. Amount received before joining employment or after cessation of employment shall be treated as Profit in lieu of salary & Taxable as IFS.

Statement Of Income from Salary

(Name of Assessee : PY 21-22 , AY- 22-23)

Particular	Notes	Amt
❖ Basic Salary	1	XX
❖ Dearness Allowance (DA)	2	XX
❖ Commission	3	XX
❖ Bonus	4	XX
❖ Advance Salary/Arrears of Salary	5	XX
❖ Gratuity	6	XX
❖ Pension	7	XX
❖ Leave Salary	8	XX
❖ Provident Fund	9	XX
❖ Super Annuation Fund	10	XX
❖ Voluntary Retirement Compensation	11	XX
❖ Retrenchment Compensation	12	XX
❖ Allowance	13	XX

❖ Perquisites	14	XX
GROSS SALARY		XXX
<u>Less: Deduction U/s 16</u>		
❖ Professional Tax	15	XX
❖ Entertainment Allowance	16	XX
❖ Standard Deduction	17	XX
NET SALARY		XXX

NOTE 1:- Basic Salary

- ❖ It is fully **Taxable**
- ❖ If net basic salary is given, then convert it into gross basic salary

NOTE 2:- Dearness Allowance (DA)

- ❖ DA is fully **taxable** whether it is 'in terms' OR not in terms'.
- ❖ In terms means forming part of retirement benefit calculation.
- ❖ In all the formula, generally DA in terms is considered.
- ❖ If nothing is mentioned then assume DA not in terms.

NOTE 3:- Commission

- ❖ Commission is fully **taxable** whether it is turnover commission or any other commission.

NOTE 4:- BONUS

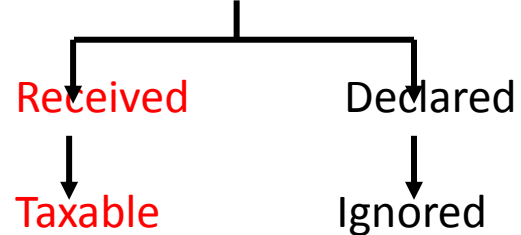

NOTE 5:- Advance Salary/ Arrears of Salary

- ❖ It is **taxable** on Receipt basis
- ❖ **Advance** or **Advance against salary** shall be **ignored** (It is a loan and not an income)

NOTE 6:- Gratuity

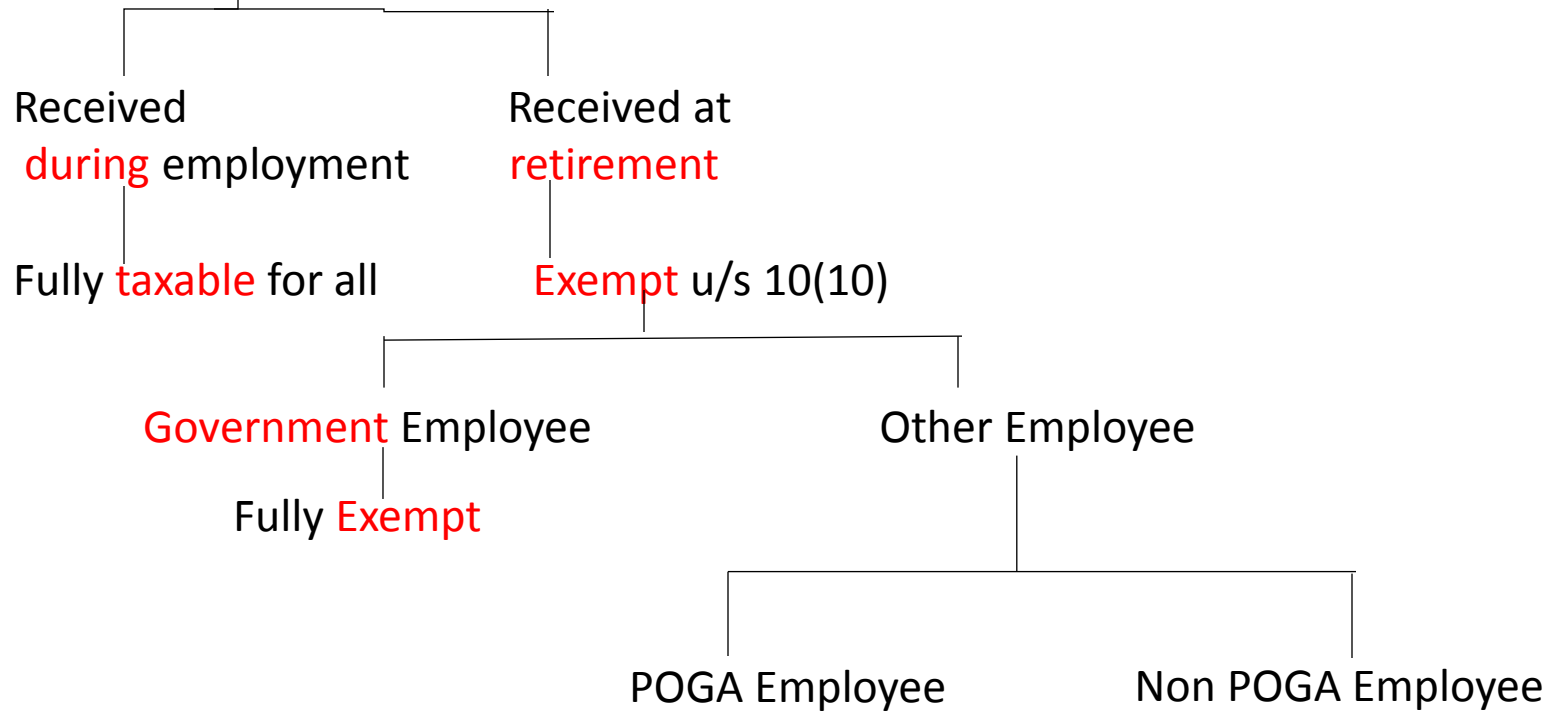

Exemption=Least of following

1. $15/26$ * salary p.m. * No. of yrs. of service
2. Actual Amt
3. Max. Rs. 20,00,000

Salary means

Latest Basic p.m. (+) Latest
DA.(Both) p.m.

Rounding off years allowed if
fraction is more than 6 month

Exempt=Least of following

1. $\frac{1}{2}$ * salary p.m. * No. of yrs service.
2. Actual Amt
3. Max. Rs. 20,00,000

Salary means

Avg. Basic [Last 10m]
(+) Avg DA(T) [Last 10m]
(+) Avg T/O Comm[Last 10m]

Rounding off years not allowed

NOTE 7:- Pension

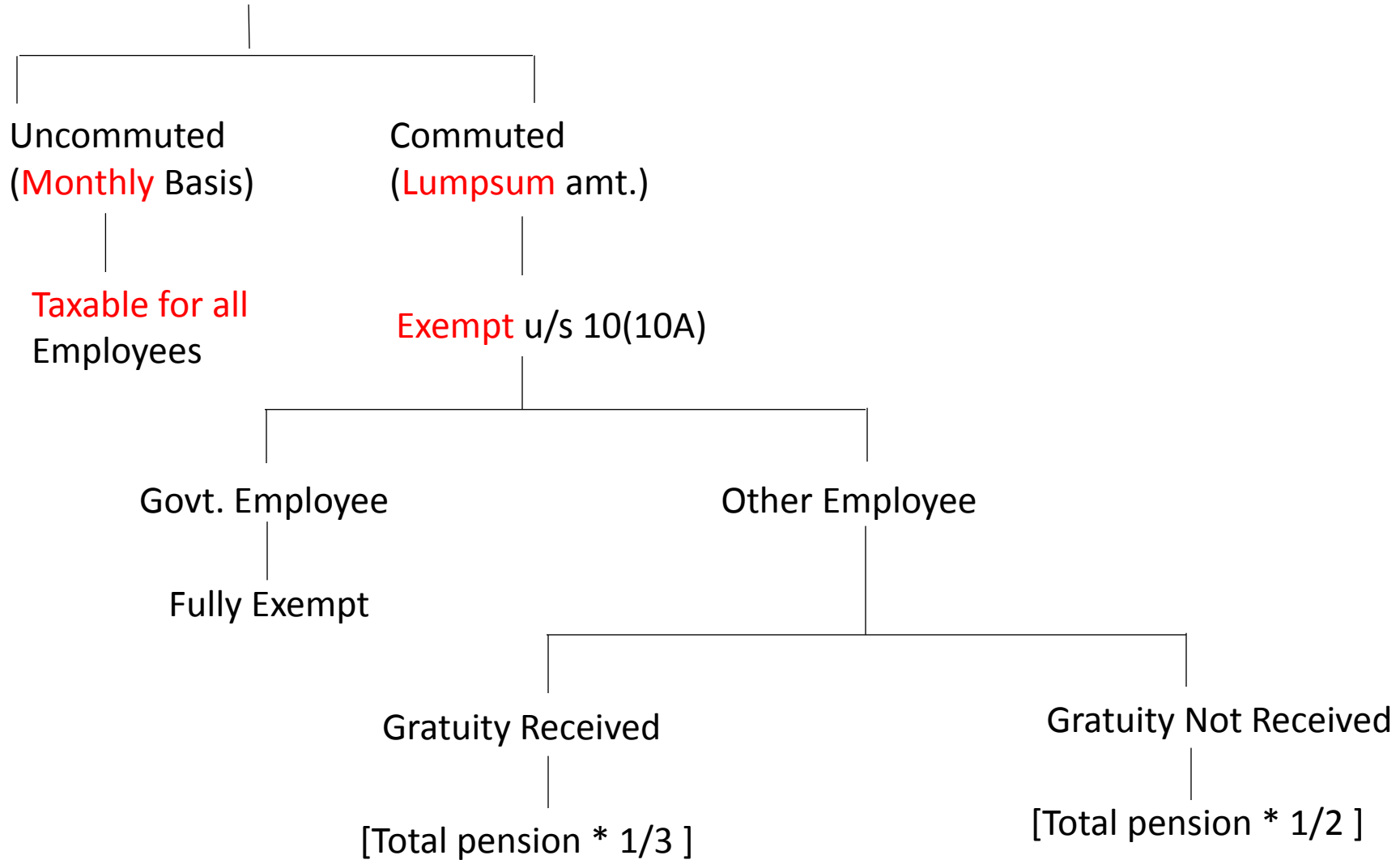

NOTE 8:- Leave Salary

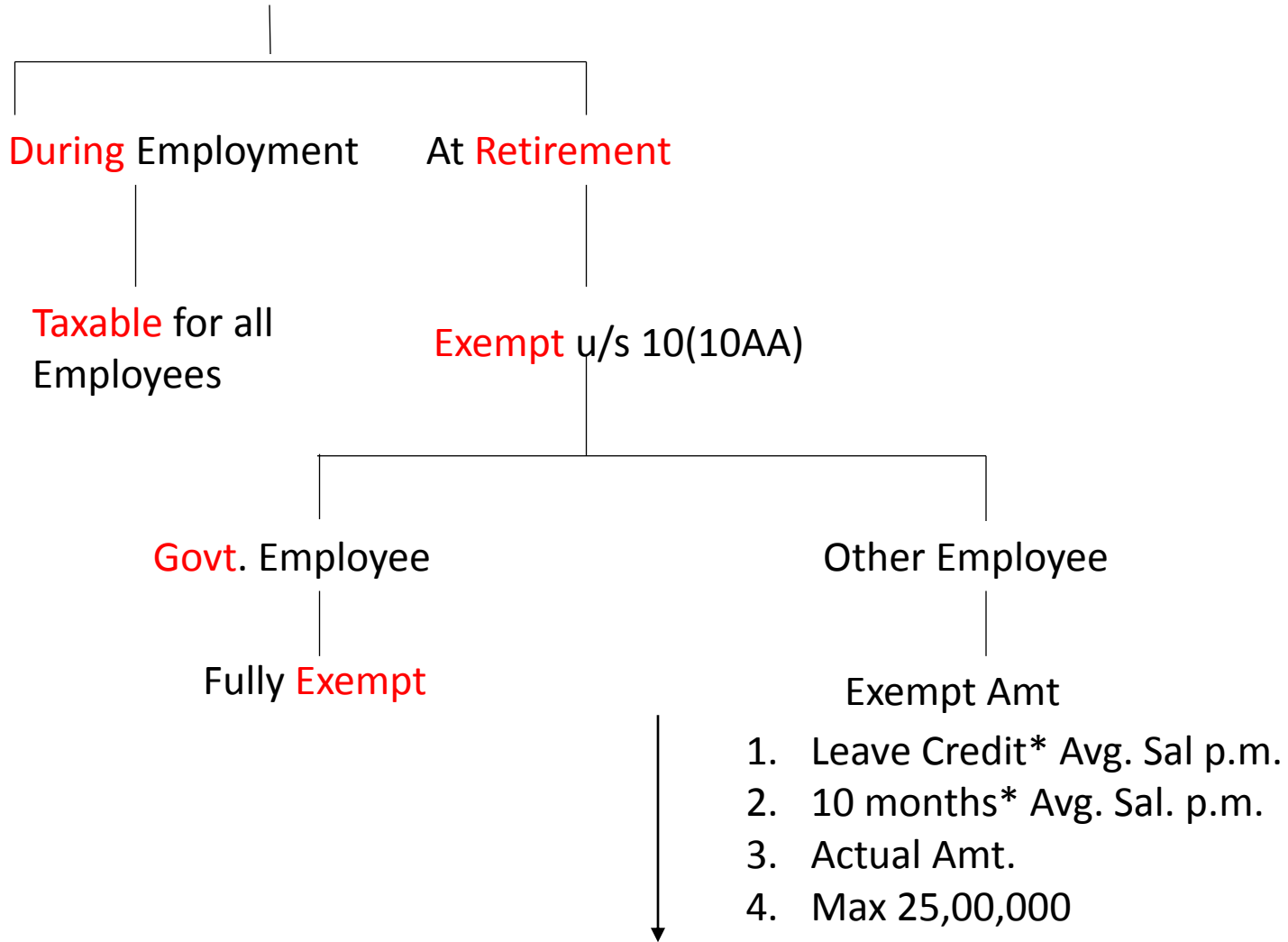

Avg sal. p.m. means

Avg Basic [Last 10 Months]

Avg DA(T) [Last 10 Months]

Avg T/O Comm [Last 10 Months]

Last 10 months up to date of retirement

Leave credit = Leave Allowed – Leave taken

Leave allowed max 30 days for every completed year of service.

NOTE 9 :- Provident Fund

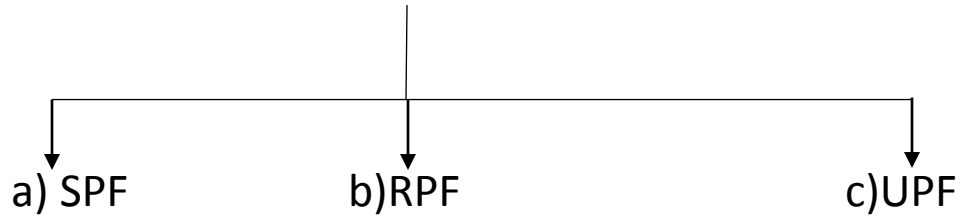

a)SPF(Statutory Provident Fund)

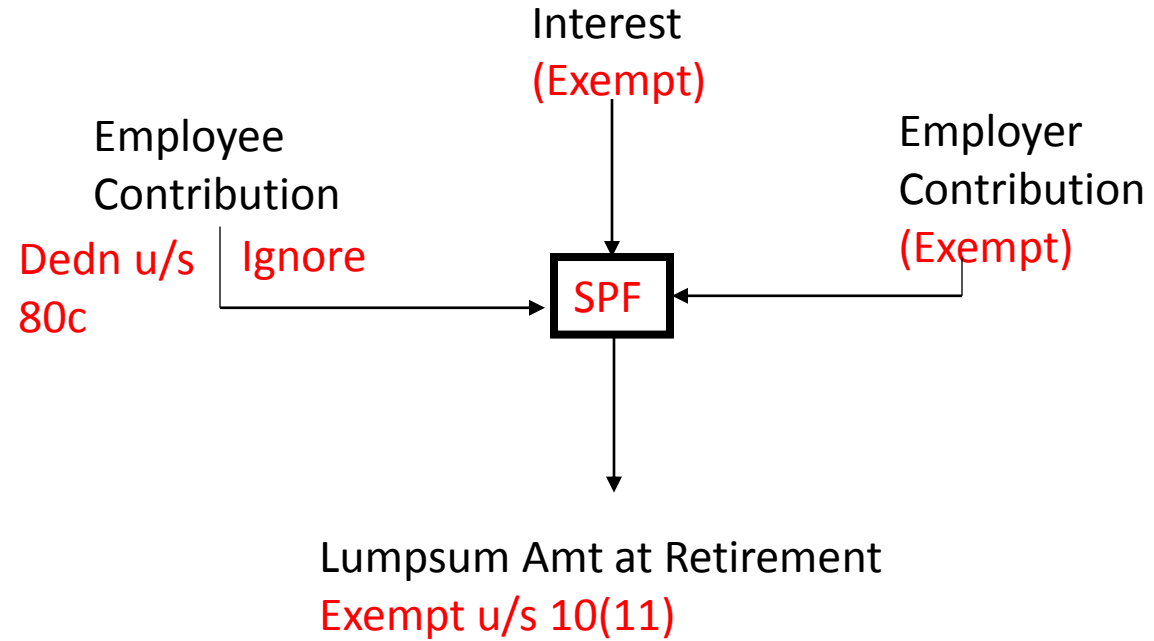

b) RPF(Recognized Provident Fund)

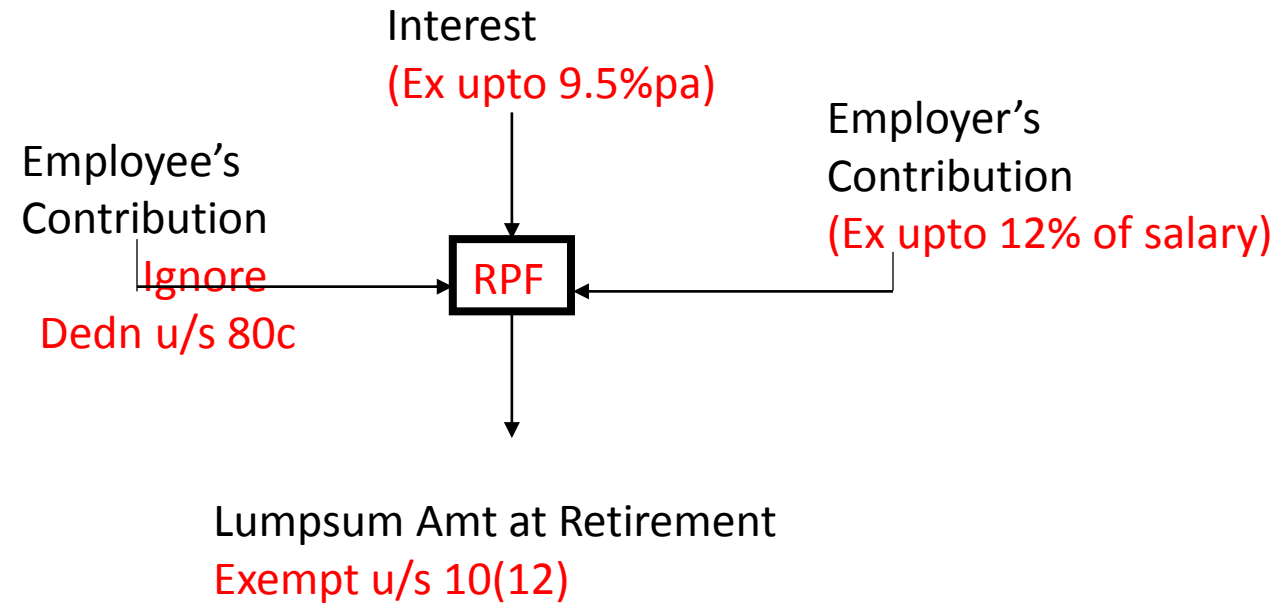

#Imp.Point

1. Lumpsum amount received from RPF is exempt if employee has rendered service of 5 year Or more.
2. If above condition is not satisfied then exemption allowed in respect of employer's contribution and Interest shall be withdrawn.
3. Exception to above condition:-
 - a) Retired due to ill health
 - b) Shutdown of employer's business
 - c) Balance in RPF is transferred to new employer.

c) UPF (Unrecognized Provident Fund)

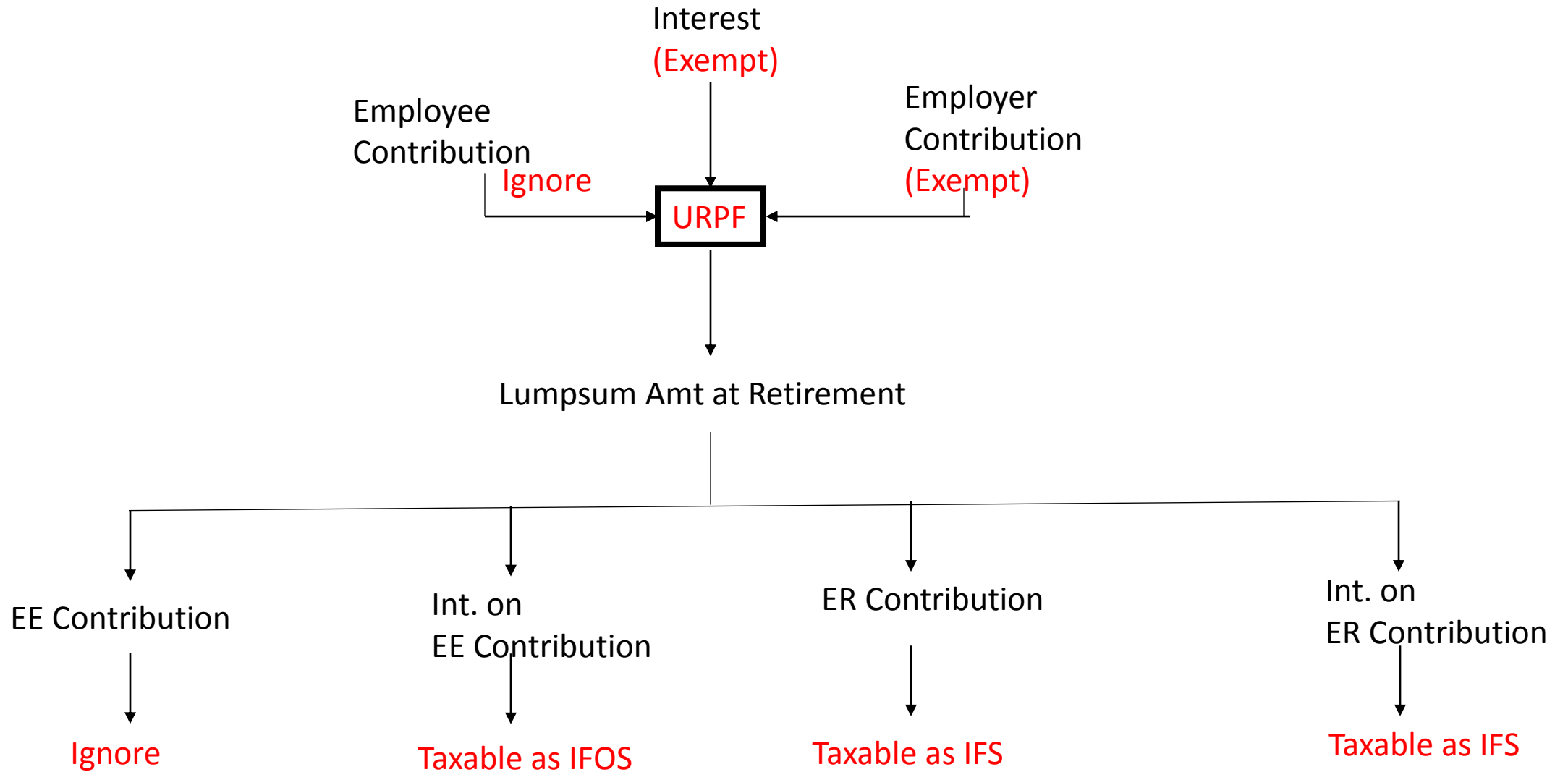

NOTE 10:- Super Annuation Fund

a) Approved Super Annuation Fund (ASF)

a) Unapproved Super Annuation Fund (ASF)

a) ASF (Approved Super Annuation Fund)

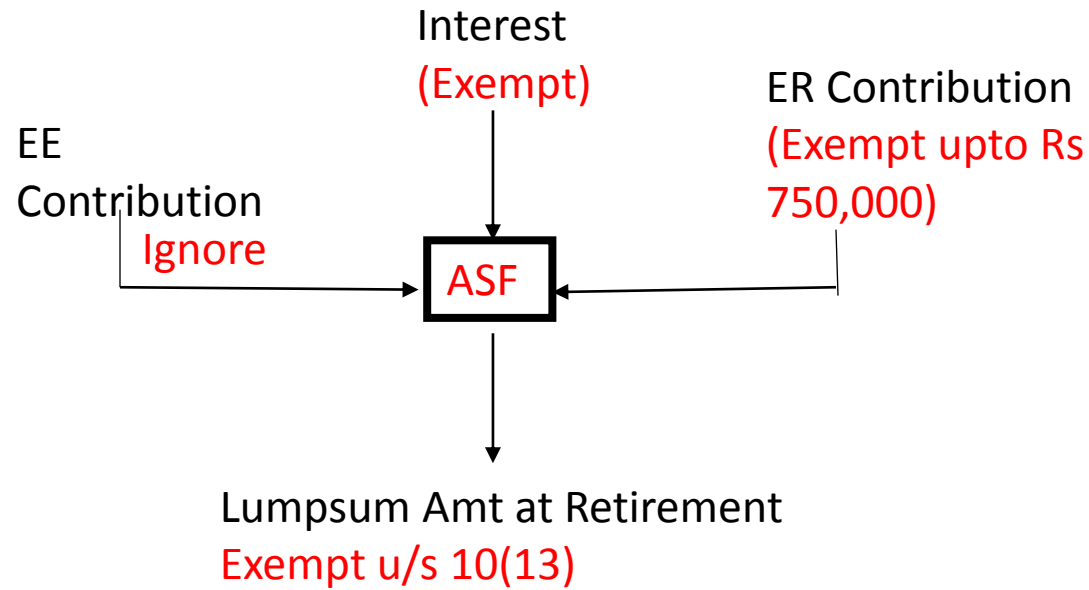

b) USF (Unapproved Super Annuation Fund)

Treated same as UPF

NOTE 11:- VRS (Voluntary Retirement Scheme)

↓
Exempt u/s 10(10 C)

- ↓
1. Sal.p.m. x 3months x No. of yrs. Completed (Ignore Fraction)
 2. Sal. p.m. x No. of Remaining months of service
 3. Actual Amt received
 4. Max. Rs 500,000

Salary p.m.= Basic + DA(T) + T/O Comm

NOTE 12:- Retrenchment Compensation

↓
Exempt u/s 10(10 B)

- ↓
1. $15/26 \times \text{Sal. p.m.} \times \text{No. of yrs.}$
 2. Compensation as per Industrial Dispute Act
 3. Max. Rs 500000

Sal. Means = Basic + DA(T) + T/O Comm

Avg. salary of last 3 months

Rounding off years is allowed if fraction is more than 6 months

NOTE 13 Allowances

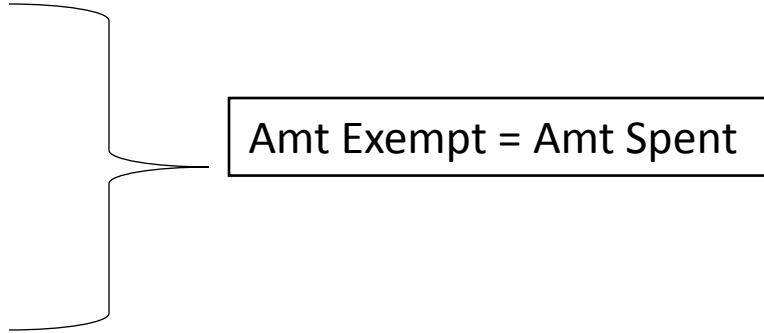
<u>Name Of Allowance</u>	<u>Exempt u/s 10(14)</u>
1. Children Education Allowance	1. Max. Rs. 100 p.m.p.c. (max 2 children)
2. Children hostel allowance	2. Max. Rs. 300 p.m.p.c. (max 2 children)
3. Underground (mines) allowance	3. Max. Rs. 800 p.m.
4. Tribal area allowance	4. Max. Rs. 200 p.m.
5. Transport (commutation)	5. Max. Rs. 3200 p.m. (If blind/deft/dumb/handicap)
6. Allowance to employee of transport undertaking	6. 70% of Amt received OR Rs 10000 (↓)
7. Travelling/Tour Allowance	
8. Conveyance Allowance	
9. Uniform Allowance	
10. Daily Allowance	
11. Helper Allowance	
12. Research Allowance	

Amt Exempt = Amt Spent

HRA (HOUSE RENT ALLOWANCE)

Exempt u/s 10(13 A)

- ↓
- a) 40%/50% of salary (BS + DA(T) + TOC)
 - b) Actual Amt Received
 - c) Rent Paid – 10% of salary (BS + DA(T) + TOC)

#Other Allowance Fully Taxable

Note 14 : Perquisites u/s 17(2)

It means personal benefit given by employer to employee. It may be monetary or non-monetary(facility).

Allowances

1. Fixed Amount is given to employee.
2. It is received whether actual expenditure incurred or not.
3. Example
Medical Allowance
Travelling Allowance etc.

Perquisites

1. Facility or personal benefit is given to employee.
2. It is received when actual expenditure incurred.
3. Example
Medical facility
Car Facility etc.

Leave Travel concession (LTC)

Exempt uls 10(5)

Travel by Air

Exempt

- 1. Actual exp
- 2. Economy-class fare (Air India)

Travel by other mode

Railway facility Available

Exempt

- 1. Actual exp
- 2. 1st Class AC Rail Fare

Railway facility Not Available

Recognised Transport facility Available

Exempt

- 1. Actual exp
- 2. Deluxe class bus fare

Recognised Transport facility not Available

Exempt

- 1. Actual exp
- 2. 1st Class AC Rail fare (of similar Distance)

Additional Point

1. LTC exemption is available for the travel of employee, spouse, children and dependent Relative (Mother Father Brother & Sister)
2. LTC exemption is available only for 2 children born on or after 1.10.1998.

1 st Time	2 nd Time	Children eligible
1 Child	2 Children	3 Children
2 Children	1 Child	2 Children

3. LTC exemption is available for 2 yrs. During the block of 4 yrs. (Current block is 2022 to 2025)

Medical facility

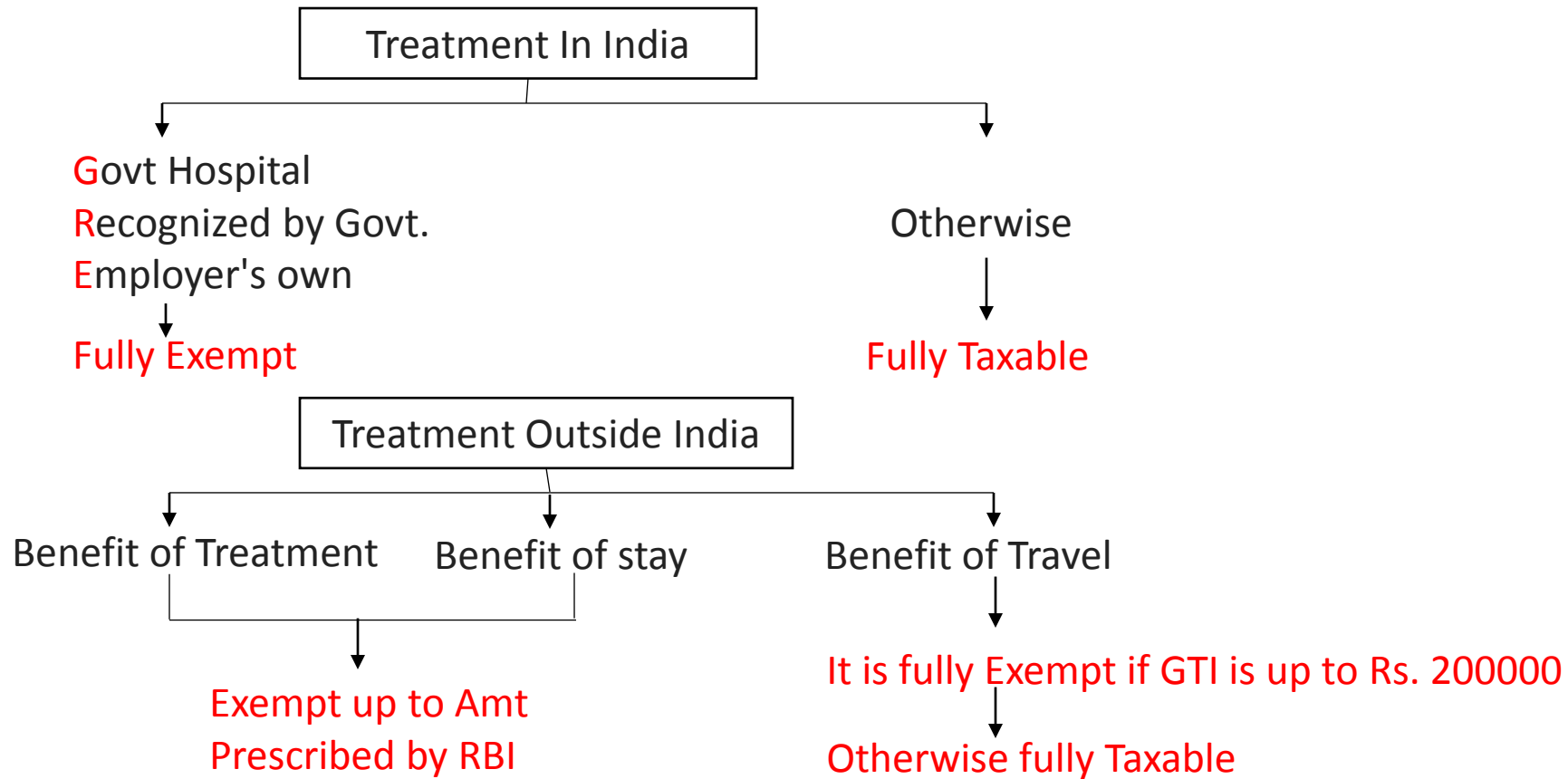

Additional Point:-

1. Medical Insurance Premiums is **fully Exempt**.
2. Exemption for treatment is allowed for employee, spouse, children & dependent relative (father, mother, Brother, sister)
3. Exemption of Stay & Travel is allowed **only** for **One** patient & **One** attendant,

Car facility

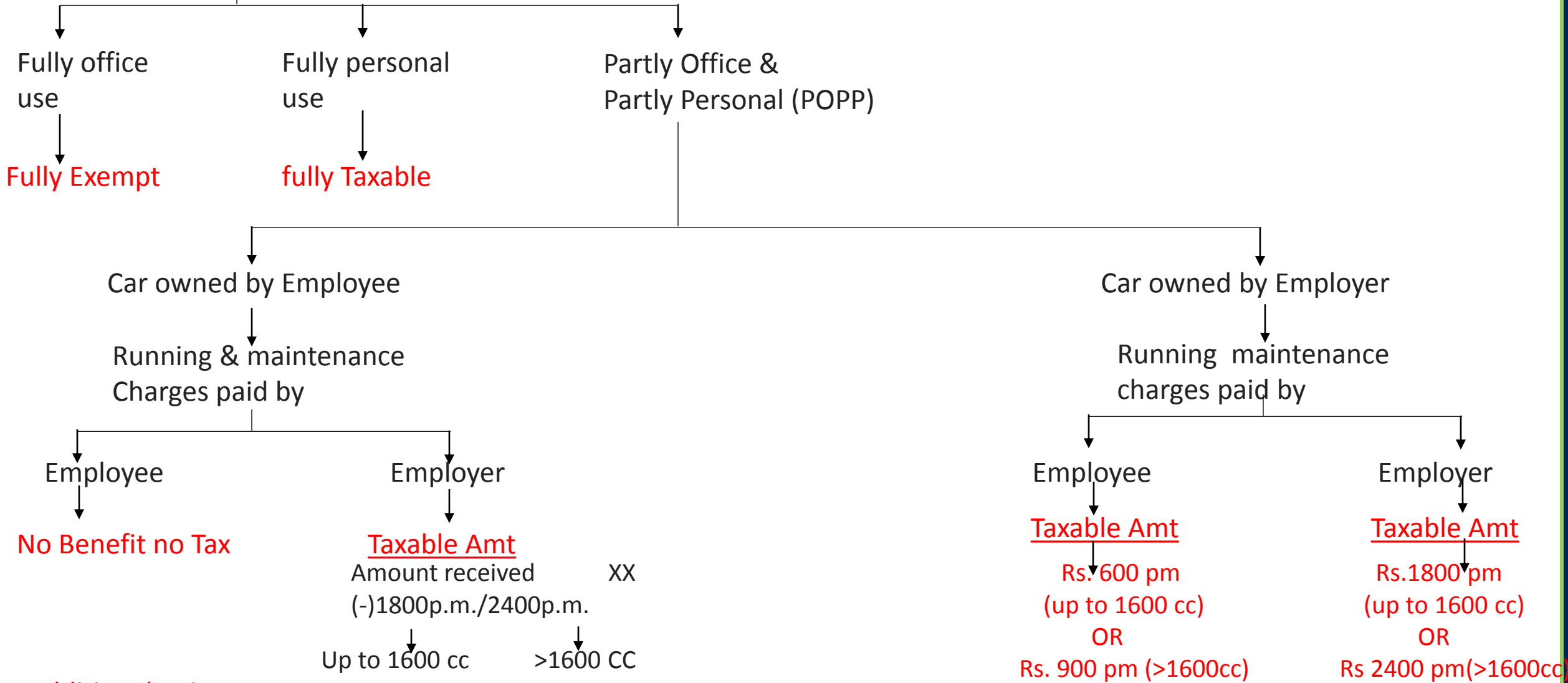

Additional Point

1. If employer provides driver, then Rs 900 pm will be added in above limits.
2. If more than 1 car is given for POPP then 1 car will be treated as per above Rule and all other cars will be treated like fully personal use.

Educational Facility

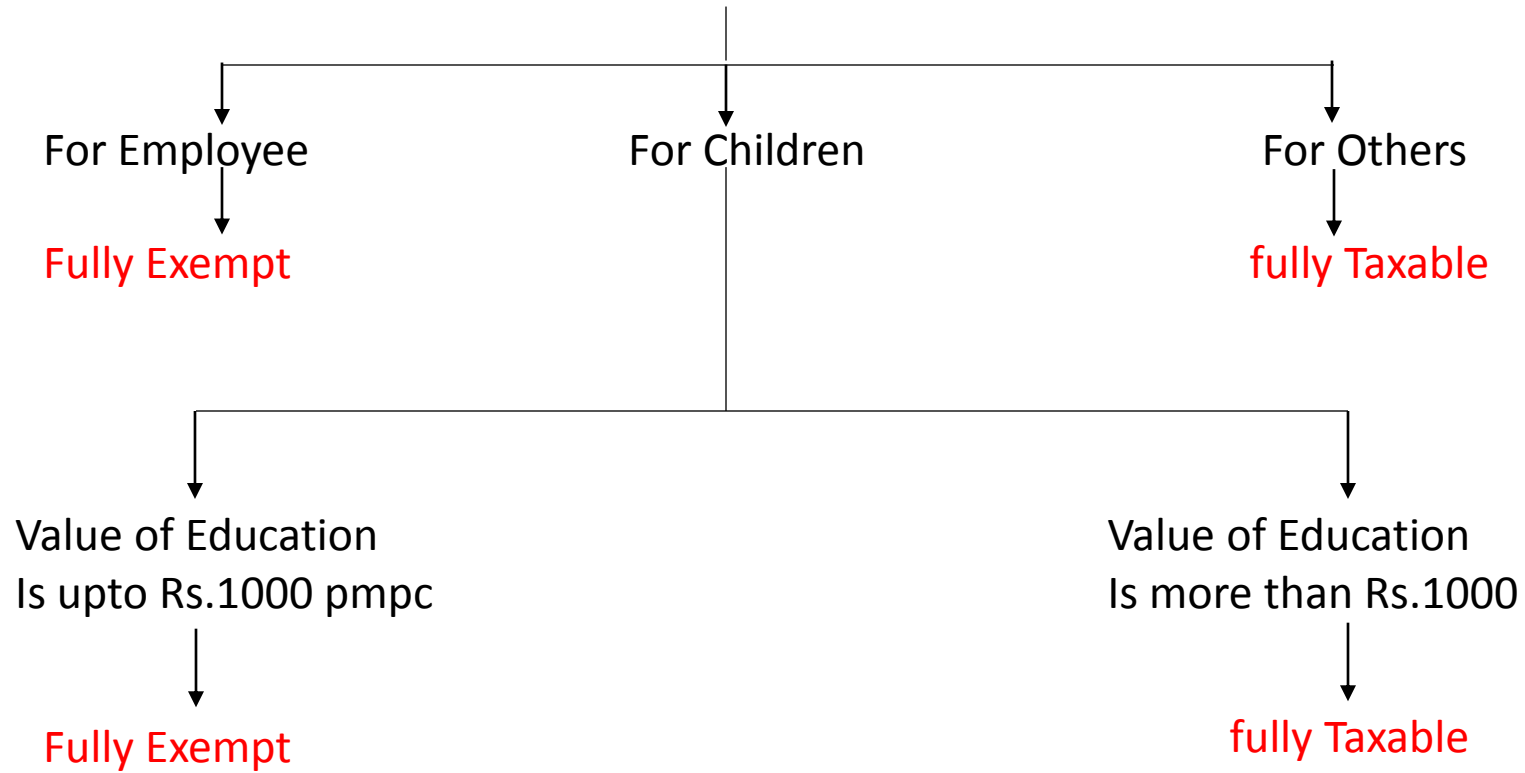

Note 15: Professional Tax

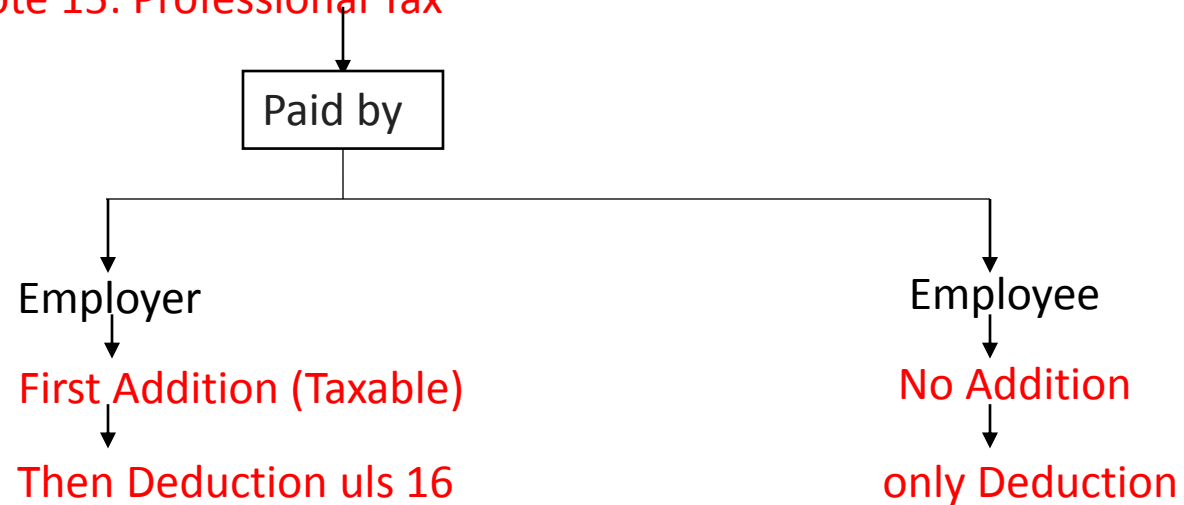

Note 16: Entertainment Allowance

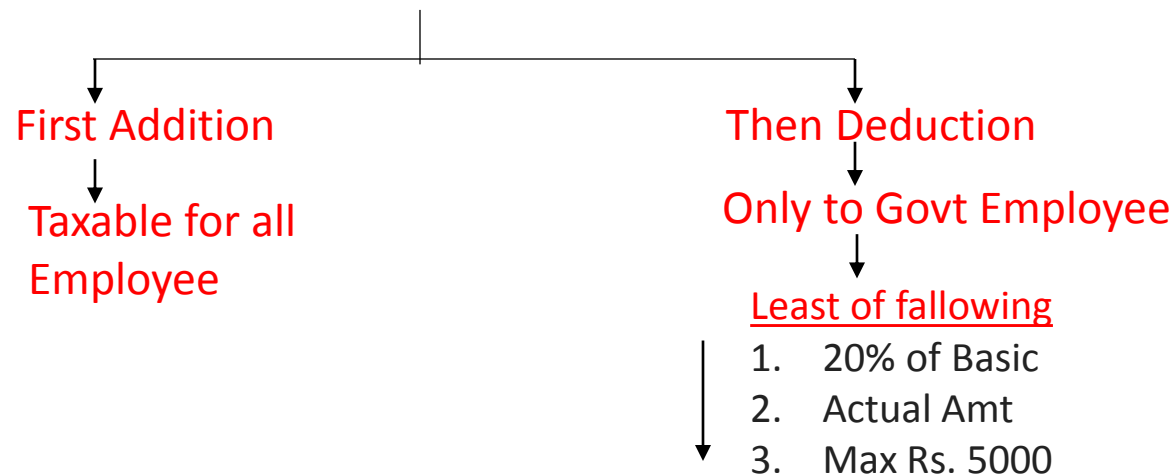

Income Tax Department



C.—Income from house property

Income from house property.

22. The annual value of property consisting of any buildings or lands appurtenant thereto of which the assessee is the owner, other than such portions of such property as he may occupy for the purposes of any business or profession carried on by him the profits of which are chargeable to income-tax, shall be chargeable to income-tax under the head "Income from house property".

INCOME FROM HOUSE PROPERTY [IFHP]

Rental Income (Annual value) is taxable under the head income from house property if following **two** conditions are satisfied:-

1. There should be **house property**.
2. Assessee should be **Owner** of that house Property

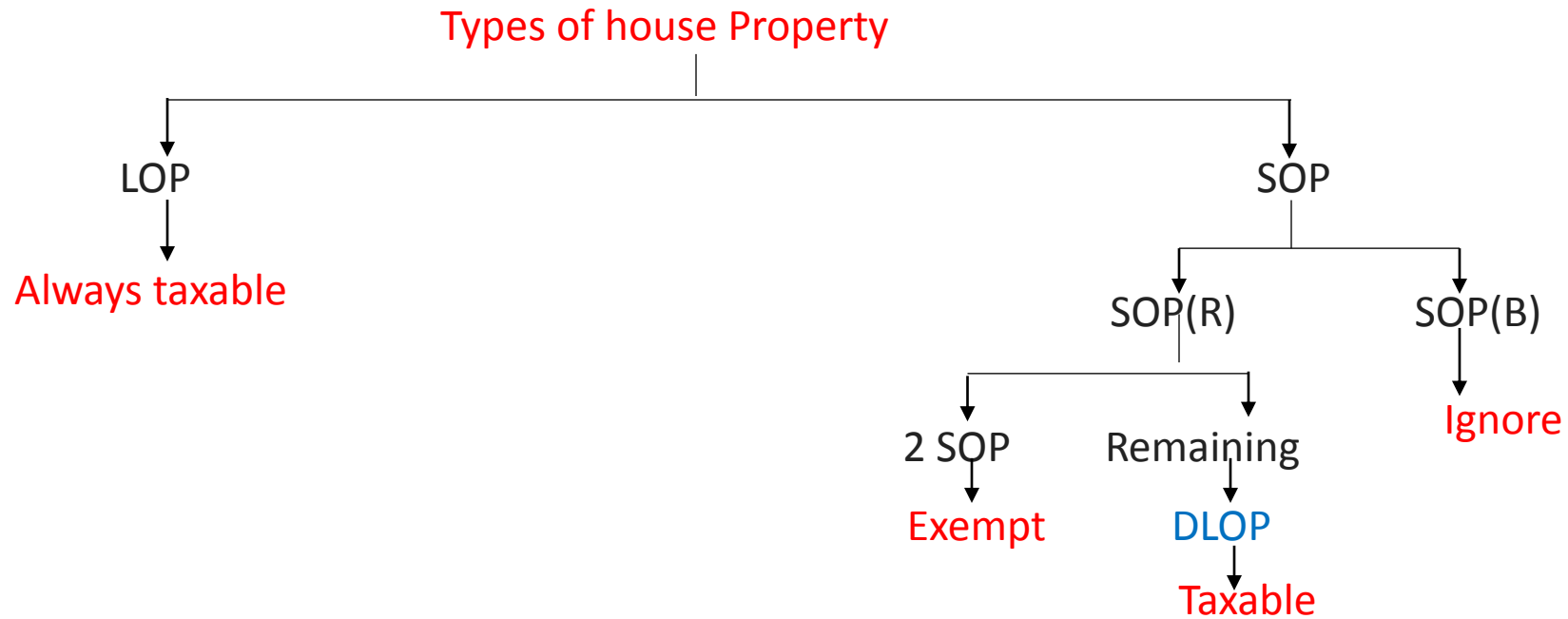

LOP = Let out property

SOP(R)= Self Occupied Property for Resident

SOP(B)= Self occupied property for Business

DLOP = Deemed to be Let out Property

Computation of Income From House Property

Particulars	SOP(R)	LOP	DLOP
↑ Municipal value	NIL	XX	XX
↓ Fair Rent	NIL	XX	XX
↓ Whichever is higher	NIL	XX	XX
↓ Standard Rent	NIL	XX	XX
↑ Expected Rent	NIL	XX	XX
↓ Actual Rent	NIL	XX	---
Gross Annual value(GAV)	NIL	XX	XX
(-) Municipal Tax Paid	NIL	XX	XX
Net Annual value (NAV)	NIL	XX	XX
(-) <u>Deduction u/s 24</u>			
(i) Standard Deduction (30 % of NAV)	NIL	(XX)	(XX)
(ii) Interest on loan	(XX)	(XX)	(XX)
Income from HP →	(XX)	XX	XX

NOTE 1: Interest On Loan

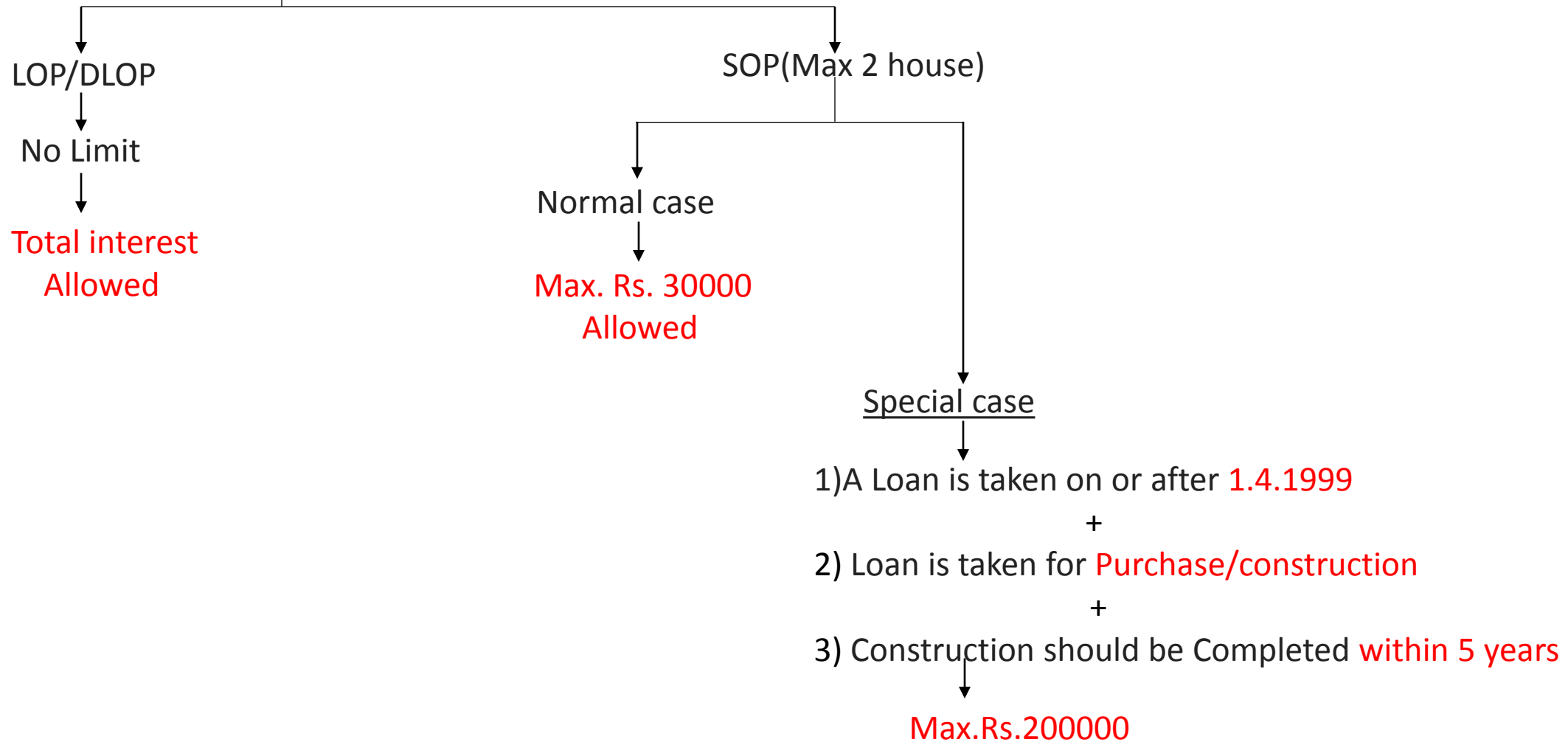

Pre-construction period interest will be allowed in 5 equal Installment from the year in which construction is completed.

Note 2: Recovery of Unrealized Rent & Arrears of Rent

It will be taxable in the year in which it is recovered whether assessee is owner or not in that previous year [Financial Year]

Taxable Amt = 70% of Recovery

Note3: Partly Let out Property [PLOP]

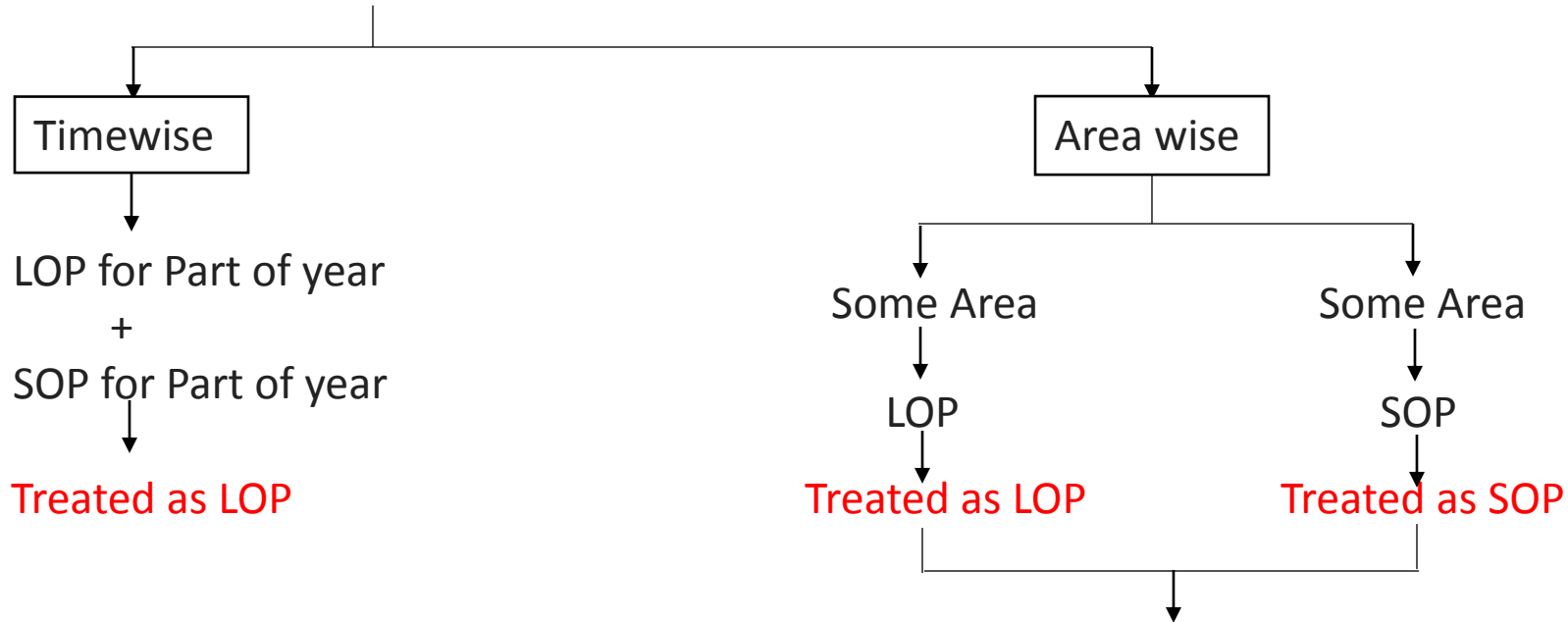

- Divide All amt in the ratio of area, except
- Actual Rent is taken in LOP Column.

NOTE 4:- Composite Rent

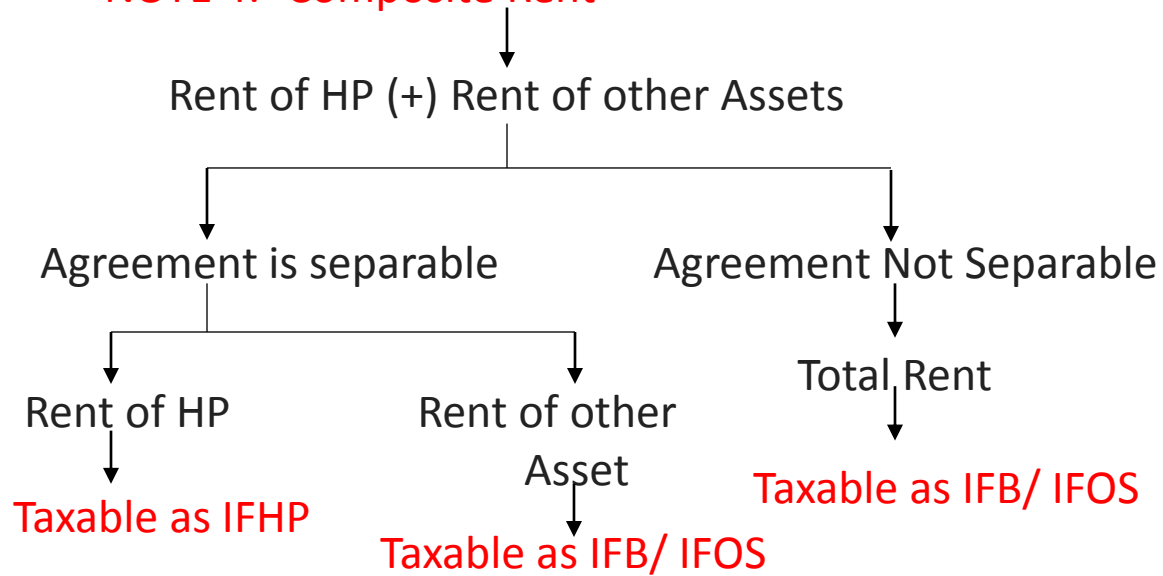

Note 5 Joint Ownership(Co-ownership)

Income from HP will be calculated Normally & thereafter it will be divided among co-owners in the ratio of ownership.

Interest on Loan

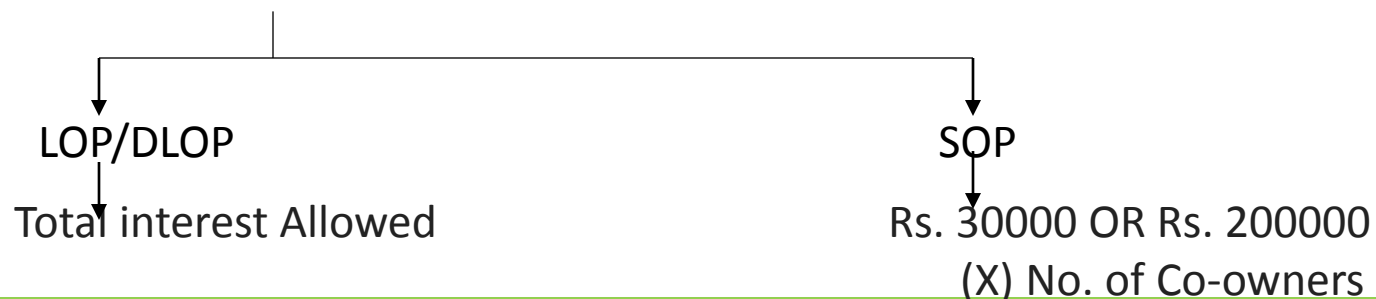

NOTE 6: Deemed Owner

1. If any individual transfers any house Property to his/her spouse for low consideration or no consideration then such individual is treated as deemed owner of such property.

Exception: Transfer in connection with Agreement to live apart.

2. If any individual transfers any house property to a minor child (other than minor married daughter) for without consideration or inadequate consideration then such individual is treated as deemed owner.

3. In case of co-operative society. shareholder is treated as deemed owner of such property.

4. Holder of an impartible estate.

Income Tax Department

*D.—Profits and gains of business or profession***Profits and gains of business or profession.**

28. The following income shall be chargeable to income-tax under the head "Profits and gains of business or profession",—

- (i) the profits and gains of any business or profession which was carried on by the assessee at any time during the previous year ;
- (ii) any compensation or other payment due to or received by,—
 - (a) any person, by whatever name called, managing the whole or substantially the whole of the affairs of an Indian company, at or in connection with the termination of his management or the modification of the terms and conditions relating thereto;
 - (b) any person, by whatever name called, managing the whole or substantially the whole of the affairs in India of any other company, at or in connection with the termination of his office or the modification of the terms and conditions relating thereto ;
 - (c) any person, by whatever name called, holding an agency in India for any part of the activities relating to the business of any other person, at or in connection with the termination of the agency or the modification of the terms and conditions relating thereto ;
 - (d) any person, for or in connection with the vesting in the Government, or in any corporation owned or controlled by the Government, under any law for the time being in force, of the management of any property or business ;
 - (e) any person, by whatever name called, at or in connection with the termination or the modification of the terms and conditions, of any contract relating to his business;
- (iii) income derived by a trade, professional or similar association from specific services performed for its members ;
- (iiia) profits on sale of a licence granted under the Imports (Control) Order, 1955, made under the Imports and Exports (Control) Act, 1947 (18 of 1947) ;
- (iiib) cash assistance (by whatever name called) received or receivable by any person against exports under any scheme of the Government of India ;
- (iiic) any duty of customs or excise re-paid or re-payable as drawback to any person against exports under the Customs and Central Excise Duties Drawback Rules, 1971 ;
- (iiid) any profit on the transfer of the Duty Entitlement Pass Book Scheme, being the Duty Remission Scheme under the export and import policy formulated and announced under section 5 of the Foreign Trade (Development and Regulation) Act, 1992 (22 of 1992) ;
- (iiie) any profit on the transfer of the Duty Free Replenishment Certificate, being the Duty Remission Scheme under the export and import policy formulated and announced under section 5 of the Foreign Trade (Development and Regulation) Act, 1992 (22 of 1992) ;
- (iv) the value of any benefit or perquisite, whether convertible into money or not, arising from business or the exercise of a profession ;
- (v) any interest, salary, bonus, commission or remuneration, by whatever name called, due to, or received by, a partner of a firm from such firm :
Provided that where any interest, salary, bonus, commission or remuneration, by whatever name called, or any part thereof has not been allowed to be deducted under clause (b) of [section 40](#), the income under this clause shall be adjusted to the extent of the amount not so allowed to be deducted ;
- (va) any sum, whether received or receivable, in cash or kind, under an agreement for—

INCOME FROM BUSINESS/PROFESSION

Statement of Income from Business [DIRECT METHOD]

Particulars	Rs.
<u>GROSS BUSINESS INCOME:</u>	
Sec 28 : Business Income	XX
Sec 41: Deemed Business Income	XX
<u>LESS : DEDUCTIONS u/s 30 to 37:</u>	
Sec 30: Rent, Rates, Repair and Insurance of Building	XX
Sec 31: Repair and Insurance of Plant and Machinery, Furniture	XX
Sec 32: Depreciation	XX
Sec.33 AB: Deduction for Tea, Coffee & Rubber Business	XX
Sec 33 ABA: Deduction for Petroleum & Natural Gas Business	XX
Sec 35 : Scientific Research	XX
sec 35 ABB: Telecommunication License Exp.	XX
Sec 35 CCC: Agriculture Extensions Project	XX
Sec 35 CCD: Skill Development Project.	XX
Sec 35 D : Preliminary Exp.	XX
Sec 35 DD: Amalgamation & Demerger Exp.	XX
Sec 35 DDA:VRS Expenses	XX

Sec 35 AD: Specified Business	XX
Sec 35 E : Expenses an Mining of coal / Iron etc.	XX
Sec 36 : Specific Deduction	XX
Sec 37 : General Deduction	XX
Taxable Income from Business (Net Profit As per Income Tax Act)	XXX

Section 28 : Charging section.

1. Profit or Gain of any business / profession.
2. Profit on sale of import entitlement license.
3. Export incentive (cash compensatory support or duty drawback)
4. Amount received under Key-man Insurance policy.
5. Gift / Benefit / Perquisite arising due to business/profession.
6. Salary/commission/ Bonus/ Interest received by partner from partnership firm [to the extent allowed u/s 40(b) to firm].
7. Non compete fees
8. Govt. Grant or Subsidy received from Govt.
9. Fair market value of stock on conversion to Capital Asset.
10. Etc.

Section 41: Deemed Business income

1. Recovery against any deduction already claimed (E.g. LBF - Insurance claim)
2. Balancing charge.
3. Sale of scientific Research Assets.
4. Recovery of Bad debts.

Sec 30 : Rent Rates Repair & Insurance of Building

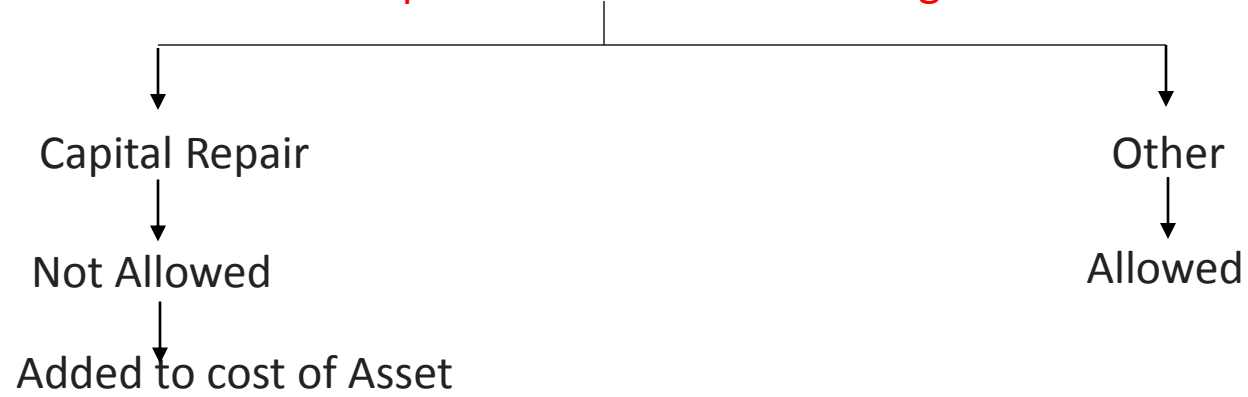

Sec. 31: Repair & Insurance of P&M and Furniture

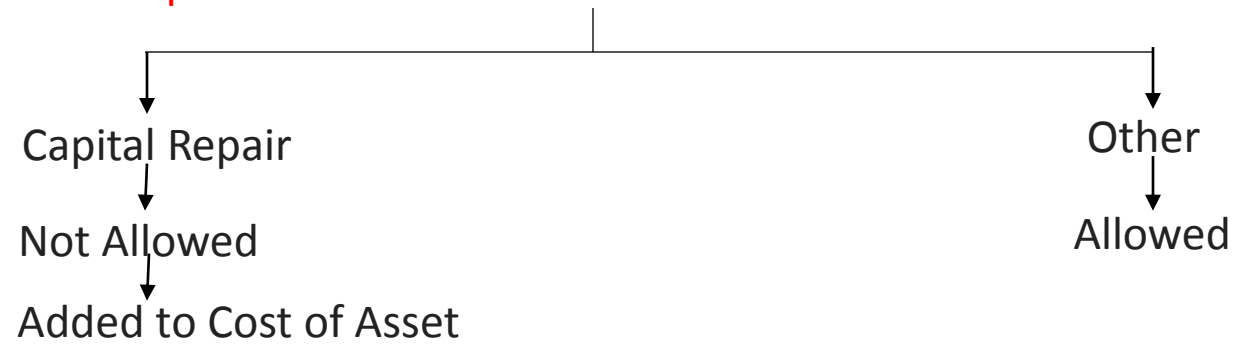

Sec 32 Depreciation.



Rates of Depreciation

Assets	Rate (%)
<u>1) Building</u>	
a) Residential	5
b) Commercial	10
c) Temporary Structure	40
<u>2) Furniture & Fitting</u>	10
<u>3) Plant & Machinery</u>	
a) <u>Motor Vehicles</u>	
i) Used for hiring business	30
Acquired & put to use [23.8.19 to 31.3.20]	45
ii) Other motor vehicle	15
Acquired & Put to use [23.8.19 to 31.3.20]	30
b) Ships	20
c) Air Craft	40
d) Computer/Laptop	40
e) Books	40
f) Windmills & it's equipment.	
Installed before 1.4.2014	15
Installed on or after 1.4.2014	40
g) Pollution control Equipment	40
h) Oil wells	15
i) Other P&M	15
<u>4) Intangible Asstes</u>	25

Calculation of Depreciation [Block of Asset]

Particulars	Rs.
Opening WDV of block	XX
Add: <u>Actual cost of Asset Acquired during PY.</u>	
Put to use for 180 days or more	XX
Put to use for less than 180 days	XX
Acquired But not put to use	XX
	XX
Less: Asset transferred [Sale Price]	XX
	XX

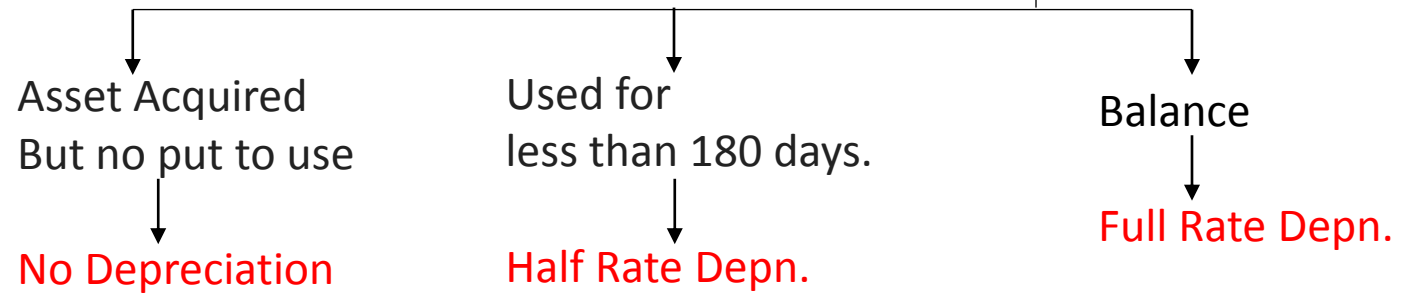

See 33 AB : Deduction for Tea, coffee & Rubber Business

- ↓ (1) Actual Amount Deposited in NABARD
- ↓ (2) [40%] of Taxable Business Income (Before this Deduction)

Sec. 33 ABA: Deduction for Petroleum & Natural Gas Business.

- ↓ (1) Actual Amount Deposited in SBI (Site Restoration A/C)
- ↓ (2) 20% of Taxable IFB (Before this deduction)

Sec. 35: Scientific Research

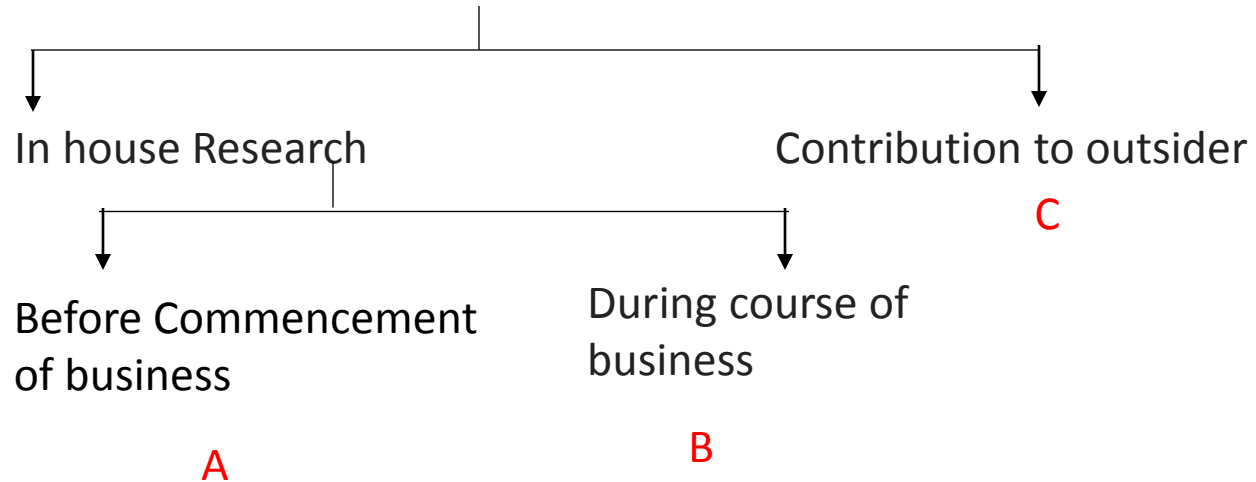

A) INHOUSE RESEARCH (BEFORE COMMENCEMENT)

(Max 3 yrs. before the date of commencement)

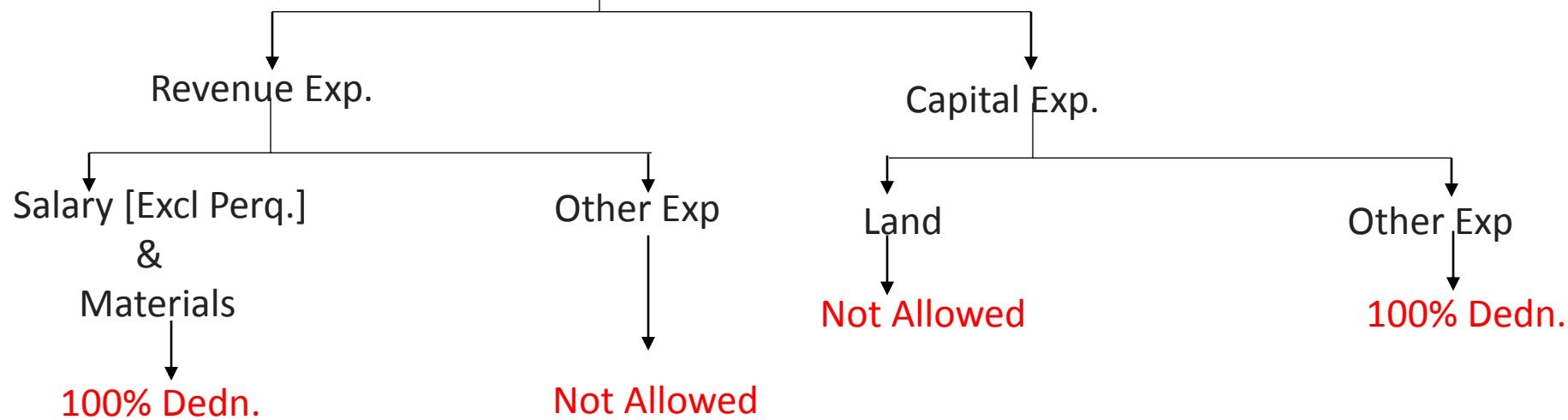

(B) INHOUSE RESEARCH(AFTER COMMENCEMENT)

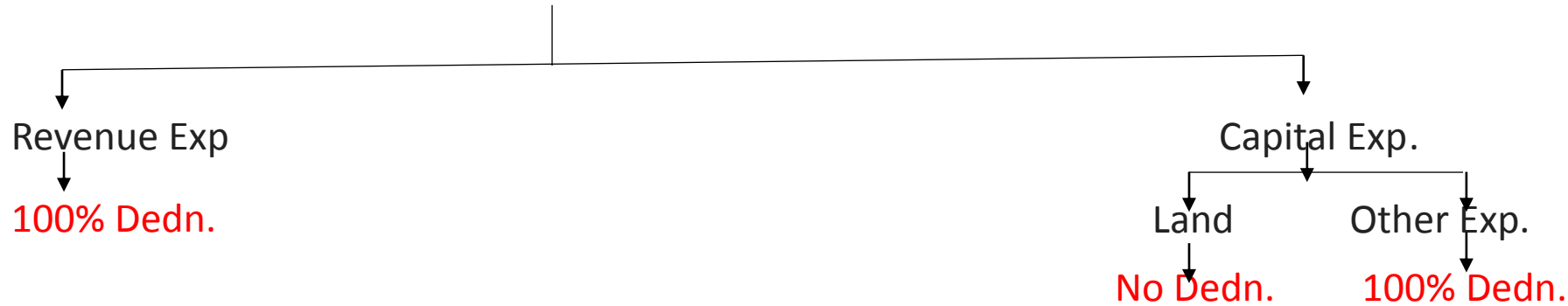

Note: If assessee is company engaged in manufacturing or Bio-technology business and Research is approved, then 100% Dedn. will be allowed for all Exp. except Land.

C) CONTRIBUTION TO OUTSIDERS

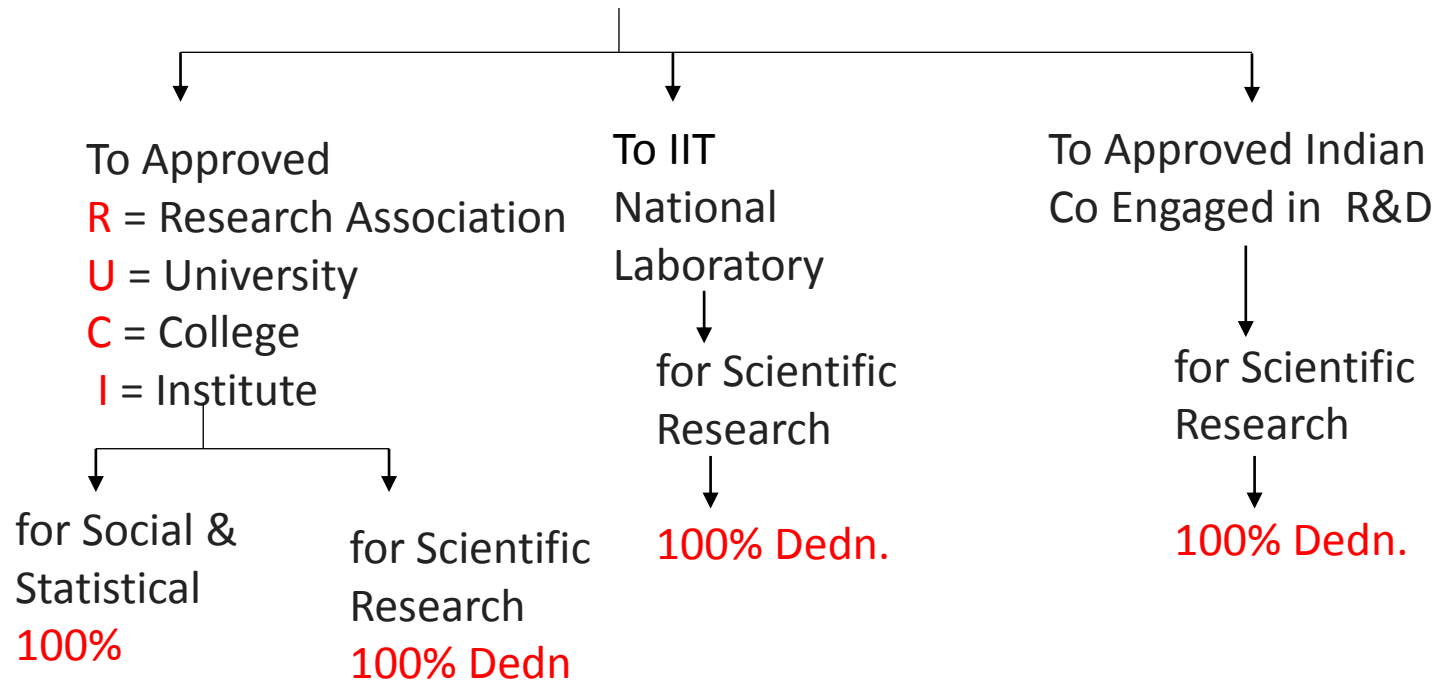

Sec 35 ABB : Telecommunication Licence

Licence obtained before commencement of business

Deduction shall be allowed from the PY in which business commences till licence expires

Licence obtained after commencement of business

Deduction shall be allowed From PY in which fees paid till licence expires

Sec 35 CCC :- Expenditure on Agriculture Extension Project

Land & Building

Not Allowed

Other Exp.

100% Dedn.

Sec 35 CCD :- Expenditure on Skill Development Project



Note :- This deduction is allowed only to companies.

Sec 35 D: Preliminary Expenses

Deduction is allowed In **5 Equal Installment**
Amount of Deduction

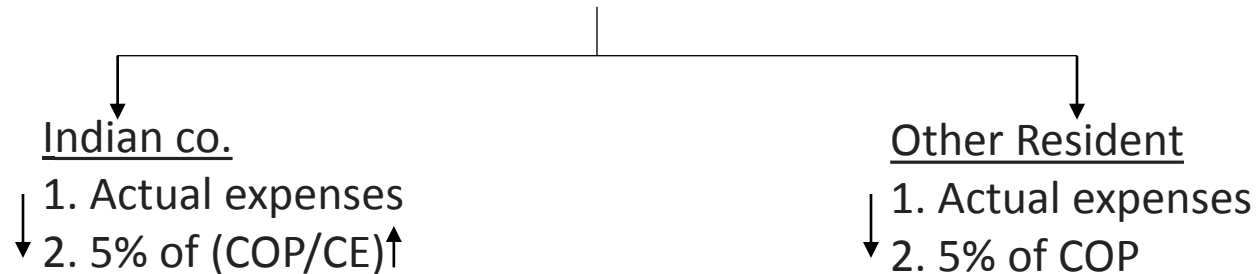

Sec 35 DDA: Expenditure on VRS

Deduction is allowed in **5 equal installment**

Sec 35 AD:- Specified Business

This section is optional for Assessee.

100% Deduction is allowed on specified business if prescribed condition are satisfied.

Specified Business

1. Cold chain facility.
2. Naturel GAS or cross country oil pipeline.
3. Hotel of 2 Star or above category.
4. Hospital with at least 100 beds for patient.
5. Housing project of Govt.
6. Production of fertilizers in India
7. Inland container Depot.
8. Honey Production
9. Warehousing facility for storage of Sugar
10. Warehousing facility for Storage of agriculture produce.
11. Slurry pipeline for transportation of Iron ore
12. Semiconductor Wafer Fabrication Manufacturing Unit
13. Developing, Maintaining & Operating New Infrastructure Facility

Sec 36: Specific Deductions

1. Insurance premium of stock.
2. Health/medical insurance premium paid for employees (other than cash).
3. Bonus or commission paid to employees.
4. Interest on loan taken for business.
5. Discount on Zero Coupon Bonds
6. Employer's contribution towards PF, Super Annuation fund, Gratuity fund etc.
7. Employer's contribution towards Pension Scheme u/s 80 CCD
8. Employee's contribution towards PF, Super Annuation fund, Gratuity fund etc.
9. Animal used in business (other than stock in trade)
10. Bad debts (Actual).
11. Family planning expenditure by Co. (Revenue 100%, Capital = 5 instalment)
12. Securities Transaction Tax (STT)/Commodities Transaction Tax (CTT)
13. Purchase of sugar cane by Co-op.Soc. engaged in manufacture of sugar
14. Marked to Market Loss or expected loss as per ICDS

Sec 37: General Deduction

Any other expenditure incurred is allowed as deduction if-

- a. It is Revenue expense & not Capital Exp.
- b. It is incurred for business & not for personal purpose.
- c. It should be legal expense.

Statement of Income from Business [INDIRECT METHOD]

Particulars	Rs.
NET PROFIT AS PER BOOKS (P&L A/C)	XXX
<u>1) ADD : DISALLOWED EXPENSES (P/L DR. X)</u>	

-----	XXX
<u>2) LESS : NON - BUSINESS INCOME (P/L CR. X)</u>	

-----	XXX
<u>3) LESS : UNRECORDED BUSINESS EXPENSES (UBE)</u>	

-----	XXX
<u>4) ADD : UNRECORDED BUSINESS INCOME (UBI)</u>	

-----	XXX
NET PROFIT AS PER INCOME TAX (TAXABLE IFB)	XXXX

Income Tax Department

E.—Capital gains

Capital gains.

45. (1) Any profits or gains arising from the transfer of a capital asset effected in the previous year shall, save as otherwise provided in [sections 54, 54B, 54D, 54E, 54EA, 54EB, 54F, 54G and 54H](#), be chargeable to income-tax under the head "Capital gains", and shall be deemed to be the income of the previous year in which the transfer took place.

(1A) Notwithstanding anything contained in sub-section (1), where any person receives at any time during any previous year any money or other assets under an insurance from an insurer on account of damage to, or destruction of, any capital asset, as a result of—

- (i) flood, typhoon, hurricane, cyclone, earthquake or other convulsion of nature; or
- (ii) riot or civil disturbance; or
- (iii) accidental fire or explosion; or
- (iv) action by an enemy or action taken in combating an enemy (whether with or without a declaration of war),

then, any profits or gains arising from receipt of such money or other assets shall be chargeable to income-tax under the head "Capital gains" and shall be deemed to be the income of such person of the previous year in which such money or other asset was received and for the purposes of [section 48](#), value of any money or the fair market value of other assets on the date of such receipt shall be deemed to be the full value of the consideration received or accruing as a result of the transfer of such capital asset.

Explanation.—For the purposes of this sub-section, the expression "insurer" shall have the meaning assigned to it in clause (9) of section 2 of the Insurance Act, 1938 (4 of 1938).

³⁰[(1B) Notwithstanding anything contained in sub-section (1), where any person receives at any time during any previous year any amount under a unit linked insurance policy, to which exemption under clause (10D) of [section 10](#) does not apply on account of the applicability of the fourth and fifth provisos thereof, including the amount allocated by way of bonus on such policy, then, any profits or gains arising from receipt of such amount by such person shall be chargeable to income-tax under the head "Capital gains" and shall be deemed to be the income of such person of the previous year in which such amount was received and the income taxable shall be calculated in such manner as may be prescribed³¹.]

(2) Notwithstanding anything contained in sub-section (1), the profits or gains arising from the transfer by way of conversion by the owner of a capital asset into, or its treatment by him as stock-in-trade of a business carried on by him shall be chargeable to income-tax as his income of the previous year in which such stock-in-trade is sold or otherwise transferred by him and, for the purposes of [section 48](#), the fair market value of the asset on the date of such conversion or treatment shall be deemed to be the full value of the consideration received or accruing as a result of the transfer of the capital asset.

(2A) Where any person has had at any time during previous year any beneficial interest in any securities, then, any profits or gains arising from transfer made by the depository or participant of such beneficial interest in respect of securities shall be chargeable to income-tax as the income of the beneficial owner of the previous year in which such transfer took place and shall not be regarded as income of the depository who is deemed to be the registered owner of securities by virtue of sub-section (1) of section 10 of the Depositories Act, 1996, and for the purposes of—

- (i) [section 48](#); and
- (ii) proviso to clause (42A) of [section 2](#),

the cost of acquisition and the period of holding of any securities shall be determined on the basis of the first-in-first-out method.

Explanation.—For the purposes of this sub-section, the expressions "beneficial owner", "depository" and "security" shall have the meanings respectively assigned to them in clauses (a), (e) and (l) of sub-section (1) of section

CAPITAL GAIN

Sec 45(1): Charging section

Capital Gain will arise if

- 1) There is **Capital Asset**
- &
- 2) **Transfer** of such Capital Asset in PY

Sec 2(14) Definition of Capital Asset :

Capital Asset means. -

- (A) Property of any kind held by assessee whether or not connected with business or profession.
- (B) Any securities held by a foreign Institutional Investor [FII].

Capital Asset Excludes :

- 1) Movable personal property.
- 2) Rural Agriculture Land in India.
- 3) Stock in trade.
- 4) Gold Deposit Bonds, 1999 or Deposit certificate issued under the Gold monetization scheme 2015.

Capital Asset includes -

- 1) Jewellery
- 2) Sculpture
- 3) Archaeological collection
- 4) Any other work of Art
- 5) Paintings / Drawings

See 2 (47): Definition of Transfer.

Transfer Includes —

- 1) The sale, exchange of the asset or relinquishment
- 2) The extinguishment of any right there in, or
- 3) Compulsory acquisition there of under any law, or
- 4) Conversion of capital asset into stock in trade or
- 5) Allowing possession of any immovable property to be taken or retained in part performance of a contract.
- 6) Any transaction (like becoming a member of, or acquiring shares in a co-op. society) which has the effect of transferring or enabling the enjoyment of immovable property.
- 7) The redemption of zero coupon Bonds (ZCB).

Sec 47: Transactions not regarded as Transfer (Exempt Transfer)

- 1) Transfer under gift, will etc. (Previous owner)
- 2) Distribution on Total / Partial Partition of HUF
- 3) Transfer Distribution under amalgamation/ merger/demerger of companies.
- 4) Transfer of capital Asset between subsidiary & holding co.
- 5) Conversion of Bond/ Debentures into shares.
- 6) Conversion of LLP or pvt. Co. into Public Co.
- 7) Transfer of capital Asset under reverse mortgage..

Types of Capital Asset

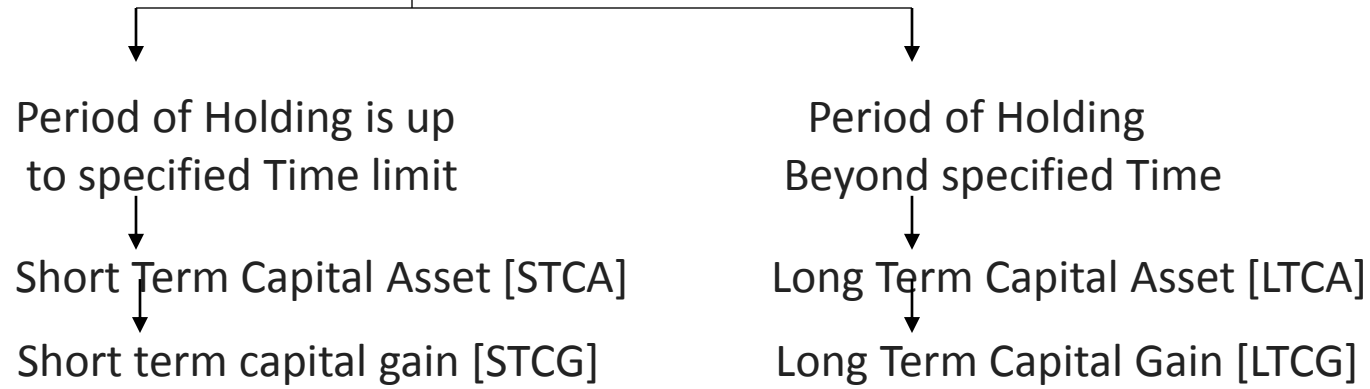

Specified Time Limit for Period of Holding

Capital Asset	Time Limit
a) Listed shares or securities in RSE in India.	1 yr.
b) Units of UTI / Equity Oriented ME.	1 yr.
c) Zero Coupon Bond	1 yr.
d) Unlisted shares.	2 yrs.
e) Immovable Property	2 yrs.
f) Any other Asset	3 yrs.

Computation of capital gain [STCG]

Particular	Rs.
Full value of consideration [FVOC]	XX
(-) Transfer Expenses.	XX
Net Consideration.	XX
(-) Cost of Acquisition [COA]	XX
(-) Cost of Improvement [COI]	XX
STCG →	<u>XXX</u>

Computation of capital Gain [LTCG]

Particular	Rs.
Full value of consideration [FVOC]	XX
(-) Transfer Expenses.	XX
Net Consideration.	XX
(-) Indexed Cost of Acquisition [ICOA]	XX
(-) Indexed Cost of Improvement [ICOI]	XX
LTCG →	<u>XXX</u>

$$\text{ICOA} = \text{Cost of Acquisition} \times \frac{\text{CII [year of Transfer]}}{\text{CII [year of Acquisition} \\ \text{Or 01-02 WEL]}}$$

$$\text{ICOI} = \text{Cost of Improvement} \times \frac{\text{CII [year of transfer]}}{\text{CII [year of Improvement]}}$$

Income Tax Department

F.—Income from other sources

Income from other sources.

56. (1) Income of every kind which is not to be excluded from the total income under this Act shall be chargeable to income-tax under the head "Income from other sources", if it is not chargeable to income-tax under any of the heads specified in [section 14](#), items *A* to *E*.

(2) In particular, and without prejudice to the generality of the provisions of sub-section (1), the following incomes, shall be chargeable to income-tax under the head "Income from other sources", namely :—

- (i) dividends ;
- (ia) income referred to in sub-clause (viii) of clause (24) of [section 2](#);
- (ib) income referred to in sub-clause (ix) of clause (24) of [section 2](#);
- (ic) income referred to in sub-clause (x) of clause (24) of [section 2](#), if such income is not chargeable to income-tax under the head "Profits and gains of business or profession";
- (id) income by way of interest on securities, if the income is not chargeable to income-tax under the head "Profits and gains of business or profession";
- (ii) income from machinery, plant or furniture belonging to the assessee and let on hire, if the income is not chargeable to income-tax under the head "Profits and gains of business or profession";
- (iii) where an assessee lets on hire machinery, plant or furniture belonging to him and also buildings, and the letting of the buildings is inseparable from the letting of the said machinery, plant or furniture, the income from such letting, if it is not chargeable to income-tax under the head "Profits and gains of business or profession";
- (iv) income referred to in sub-clause (xi) of clause (24) of [section 2](#), if such income is not chargeable to income-tax under the head "Profits and gains of business or profession" or under the head "Salaries";
- (v) where any sum of money exceeding twenty-five thousand rupees is received without consideration by an individual or a Hindu undivided family from any person on or after the 1st day of September, 2004 but before the 1st day of April, 2006, the whole of such sum :

Provided that this clause shall not apply to any sum of money received—

- (a) from any relative; or
- (b) on the occasion of the marriage of the individual; or
- (c) under a will or by way of inheritance; or
- (d) in contemplation of death of the payer; or
- (e) from any local authority as defined in the *Explanation* to clause (20) of [section 10](#); or
- (f) from any fund or foundation or university or other educational institution or hospital or other medical institution or any trust or institution referred to in clause (23C) of [section 10](#); or
- (g) from any trust or institution registered under ⁶⁴[section 12AA](#) or [section 12AB](#)].

Explanation.—For the purposes of this clause, "relative" means—

- (i) spouse of the individual;
- (ii) brother or sister of the individual;

Computation of Income from other sources	Rs.	Rs.
➤ Agricultural income from countries other than India		XX
➤ Salary of MP/MLA/MLC		XX
➤ Award	XX	
Less: Exempt u/s 10(17) if received from Govt.	XX	XX
➤ Bank interest		XX
➤ Dividend income	XX	
Less: Interest on loan up to 20%	XX	XX
➤ Winning from lottery etc.		XX
➤ Employees' contribution to PF	XX	
Less: Paid/Credited within due date	XX	XX
➤ Interest on securities	XX	
Less: Exempt u/s 10 (15)	XX	
Less: Realisation charges/interest on loan	XX	XX
➤ Rent from Machinery/Furniture	XX	
Less: Repair/Insurance/Depreciation	XX	XX
➤ Family pension	XX	
Less: Standard deduction (lower of 1/3 or 15000)	XX	XX
➤ Gifts (more than rupees 50000 from non - relative)		XX
➤ Keyman insurance policy		XX
➤ Shares of Private company without consideration		XX
➤ Premium on shares by private company		XX
➤ Interest on compensation/enhanced compensation	XX	
Less: 50% of such interest	XX	XX
➤ Advance for transfer of capital asset forfeited		XX
➤ Any other income which is not taxable under any other heads and not exempt		XX
TAXABLE INCOME FROM OTHER SOURCES		XXX

Deduction under chapter VI-A	Rs.	Rs.
Section 80 C : Investments		150000
Life insurance premium	XX	
Deferred annuity	XX	
Deferred annuity by government	XX	
Contribution to PPF/SPF/RPF/SAF	XX	
Post office cumulative time deposit	XX	
National saving scheme (NSS)	XX	
National saving certificate (NSC)	XX	
Unit Linked Insurance Plan (ULIP)	XX	
Equity Linked Saving Scheme (ELSS)	XX	
Dhanraksha	XX	
Jivan Dhara/Jivan akshay	XX	
Pension fund of MF/UTI	XX	
Home loan account of national housing Bank	XX	
Housing finance deposits	XX	
Repayment of Principal amount of Housing Loan	XX	
Tuition fees	XX	
Infrastructure debentures/shares/units	XX	
Bank FD for 5 years	XX	
NABARD Bond	XX	
Senior citizen saving scheme	XX	
Post office 5 years time deposit	XX	XXX
Section 80 CCC : Investments		150000
Premium for pension plan of LIC	XX	
Section 80 D : Medical insurance		
Self/Spouse/dependent children		25000
Parents		25000
Additional (senior citizen)		25000
Section 80 DD : Maintenance of Handicapped	75000/125000	
Section 80 E : Interest on higher education loan	INTEREST AMT.	
Section 80 TTA : Interest on deposit in saving account		10000
Section 80 TTB : Interest on deposit in saving account (senior citizen)		50000
Section 80 U : Blind/Handicapped/Retarded	75000/125000	
Total deductions (Limited To Adjusted GTI=GTI-LTCG-WINNINGS)		XXX

A vibrant, multi-colored paint splatter background. The splatters are in shades of purple, blue, cyan, green, yellow, orange, and red, all set against a white background. The text "Thank You!" is written in a bold, white, 3D-style font, centered horizontally across the middle of the splatter area.

Thank You!